

# VMMK-2403

## 2 to 4 GHz GaAs High Linearity LNA in Wafer Scale Package



### Preliminary Datasheet

#### Description

Avago's VMMK-2403 is an easy-to-use, high linearity low noise amplifier in a miniaturized wafer-scale SMT package. The low noise and unconditionally stable performance makes this amplifier ideal as a primary or subsequent gain block of a RF receiver in applications from 2–4GHz.. A 3V, 38mA power supply is required for optimal performance. This amplifier is fabricated with enhancement E-pHEMT technology and industry leading revolutionary chip scale package. The GaAsCap wafer scale sub-miniature leadless package is small and ultra thin yet can be handled and placed with standard 0402 pick and place assembly. This product is easy to use since it requires only positive DC voltages for bias and no matching coefficients are required for impedance matching to 50 Ω systems

WaferCap™ 0402, 1mm x 0.5mm x 0.25 mm

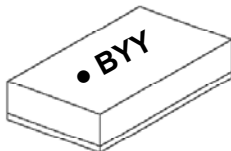

#### Pin Connections (Top View)

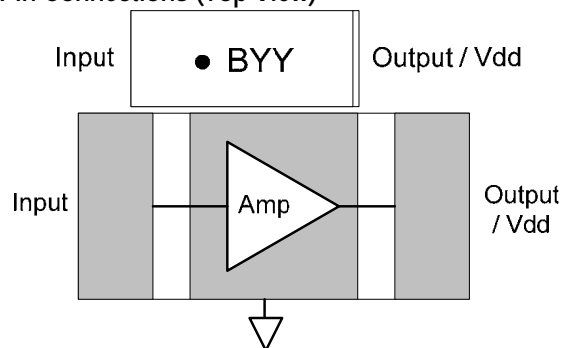

#### Note:

“B” = Device Code

“YY” = Year Code

[www.avagotech.com](http://www.avagotech.com)

Avago, Avago Technologies, and the A logo are trademarks of Avago Technologies, Pte. in the United States and other countries. Copyright © 2006 Avago Technologies Pte. All rights reserved.

*Pre-released products: Avago Technologies reserves the right to alter specifications, features, functions, markings, manufacturing release dates and general availability of the product at any time, including the right not to release the product shown in this preliminary datasheet*

Revision 1.44

#### Features

- **1 x 0.5 mm Surface Mount Package**
- **Low height (0.25mm)**
- **Unconditionally Stable**
- **50Ohm Input and Output Match**

#### Specifications (Vdd = 3.0V, Idd = 38mA)

- **RF Frequencies: 2- 4 GHz**
- **Output IP3: 29dBm**
- **Small-Signal Gain: 15dB**
- **Noise Figure: 1.8dB**

#### Applications

- **2.4 GHz, 3.5GHz WLAN and WiMax notebook computer, access point and mobile wireless applications**
- **802.16 & 802.20 BWA systems**
- **Military Radar, radio and ECM systems**



#### Attention:

Observe precautions for handling electrostatic sensitive devices.

ESD Machine Model (Class A)

ESD Human Body Model (Class 1A)

Refer to Avago Application Note A004R:

Electrostatic Discharge Damage and Control



Table 1. Absolute Maximum Ratings

Sym	Parameters/Condition	Unit	Absolute Max
Vd	Supply Voltage (RF Output) <sup>[2]</sup>	V	10
Id	Device Current ) <sup>[2]</sup>	mA	70 mA
P <sub>in, max</sub>	CW RF Input Power (RF Input) <sup>[3]</sup>	dBm	+20 dBm
P <sub>diss</sub>	Total Power Dissipation	mW	300 mW
T <sub>ch</sub>	Max channel temperature	°C	+150
T <sub>STG</sub>	Storage Temperature	°C	+150
θ <sub>jc</sub>	Thermal Resistance <sup>[4]</sup>	°C/W	160

Notes

1. Operation of this device above any one of these parameters may cause permanent damage
2. Bias is assumed DC quiescent conditions
3. With the DC (typical bias) and RF applied to the device at board temperature T<sub>b</sub>= 25°C
4. Thermal resistance is measured from junction to board using IR method

Table 2. DC and RF Specifications

T<sub>A</sub>= 25°C, Frequency = 3 GHz, Vd = 3V , I<sub>d</sub>=38mA, Z<sub>in</sub>=Z<sub>out</sub>=50Ω (unless otherwise specified)

Sym	Parameters/Condition	Unit	Minimum	Typ.	Maximum
Id	Device Current	mA	30	38	45
NF <sup>[1,2]</sup>	Noise Figure	dB	-	1.8	2.3
Ga <sup>[1,2]</sup>	Associated Gain	dB	12	15	17
OIP3 <sup>[1,2,3]</sup>	Output 3rd Order Intercept	dBm	+25	+29	-
P-1dB <sup>[1,2]</sup>	Output Power at 1dB Gain Compression	dBm	+13	+16.5	-
IRL <sup>[1,2]</sup>	Input Return Loss	dB	-	-12	-
ORL <sup>[1,2]</sup>	Output Return Loss	dB	-	-12	-

Notes:

1. In test board, circuit losses have been de-embedded from actual measurements
2. Measure Data obtained using 300um G-S-G PCB substrate
3. OIP3 test condition: F1=3.0GHz, F2=3.01GHz, Pin=-20dBm

Product Consistency Distribution Charts at 3.0 GHz, Vd = 5 V

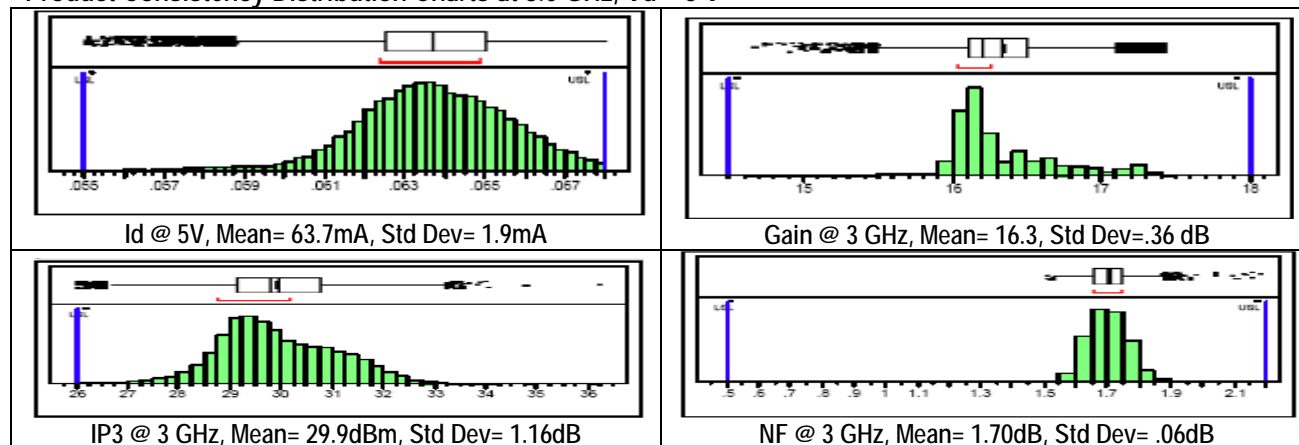

Note: Distribution data based on 500 part sample size from skew lots during initial characterization.

[www.avagotech.com](http://www.avagotech.com)

Avago, Avago Technologies, and the A logo are trademarks of Avago Technologies, Pte. in the United States and other countries. Copyright © 2006 Avago Technologies Pte. All rights reserved.



Pre-released products: Avago Technologies reserves the right to alter specifications, features, functions, markings, manufacturing release dates and general availability of the product at any time, including the right not to release the product shown in this preliminary datasheet

## VMMK-2403 Typical Performance <sup>[1], [2]</sup>

( $T_A = 25^\circ\text{C}$ ,  $V_{dd} = 3\text{V}$ ,  $I_{dd} = 38\text{mA}$ ,  $Z_{in} = Z_{out} = 50\ \Omega$  unless noted)

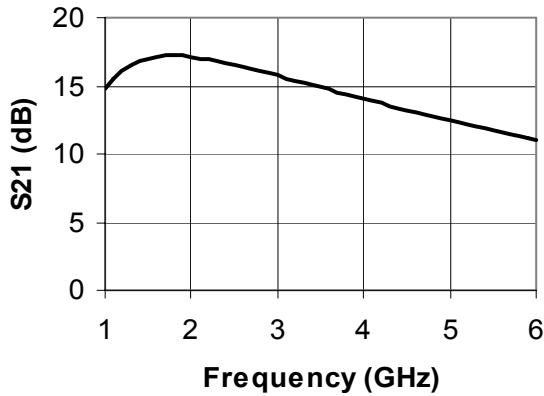

Figure 1. Small-signal Gain

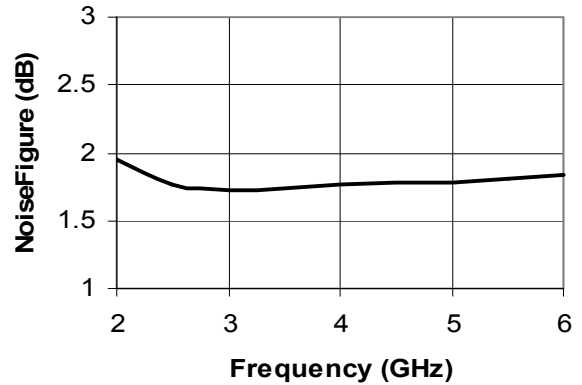

Figure 2. Noise Figure

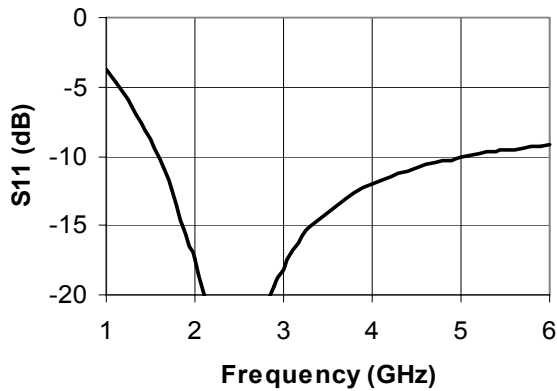

Figure 3. Input Return Loss

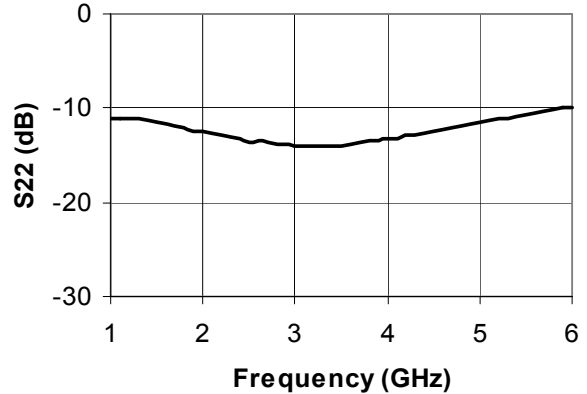

Figure 4. Output Return Loss

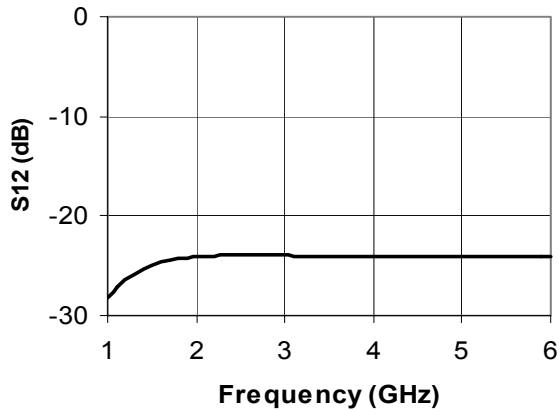

Figure 5. Isolation

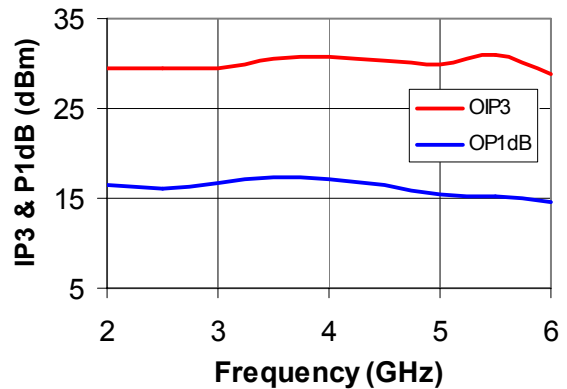

Figure 6. Output IP3 & Output P1dB

### Note:

[1] S-parameters are measured on a fully de-embedded test fixture

[2] Noise Figure is measured on a fully de-embedded test fixture in 50-Ohm environment

[www.avagotech.com](http://www.avagotech.com)

Avago, Avago Technologies, and the A logo are trademarks of Avago Technologies, Pte. in the United States and other countries. Copyright © 2006 Avago Technologies Pte. All rights reserved.

*Pre-released products: Avago Technologies reserves the right to alter specifications, features, functions, markings, manufacturing release dates and general availability of the product at any time, including the right not to release the product shown in this preliminary datasheet*

## VMMK-2403 Typical Performance (cont)

( $T_A = 25^\circ\text{C}$ ,  $V_{dd}=3\text{V}$ ,  $I_{dd}=38\text{mA}$ ,  $Z_{in} = Z_{out} = 50\ \Omega$  unless noted)

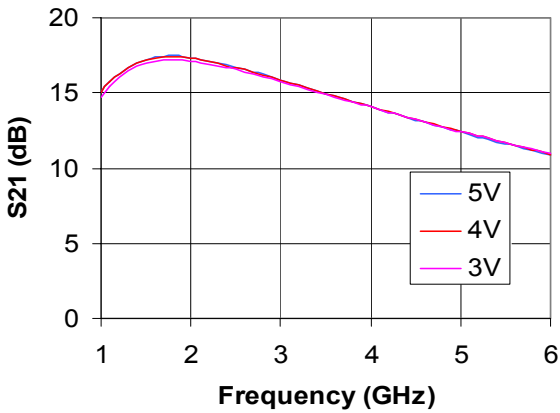

Figure 7. Gain over Vdd

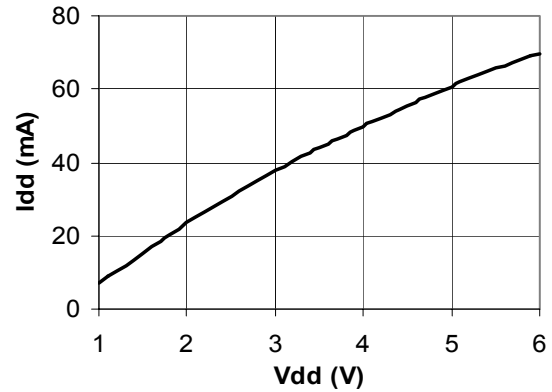

Figure 8. Total Current

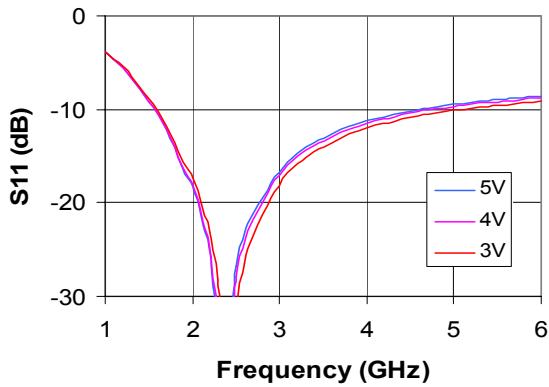

Figure 9. Input Return Loss over Vdd

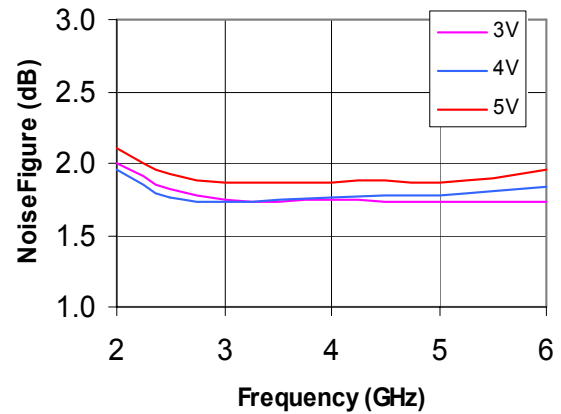

Figure 10 Noise Figure over Vdd

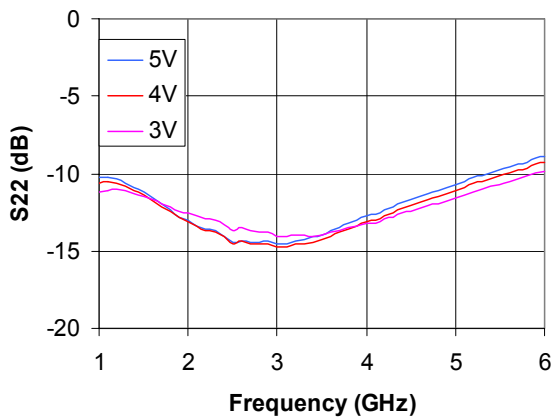

Figure 11. Output Return Loss Over Vdd

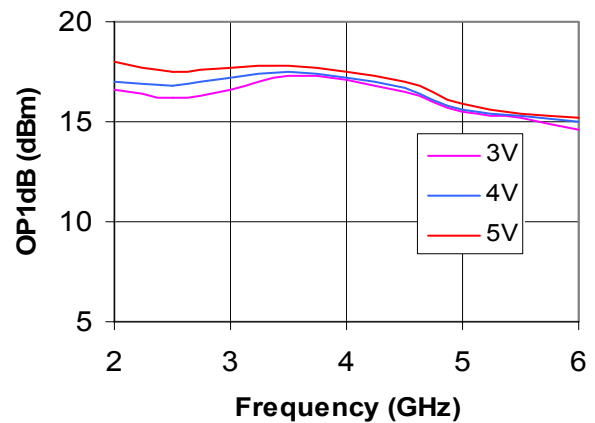

Figure 12. Output P1dB Over Vdd

[www.avagotech.com](http://www.avagotech.com)

Avago, Avago Technologies, and the A logo are trademarks of Avago Technologies, Pte. in the United States and other countries. Copyright © 2006 Avago Technologies Pte. All rights reserved.

**AVAGO**  
TECHNOLOGIES

Pre-released products: Avago Technologies reserves the right to alter specifications, features, functions, markings, manufacturing release dates and general availability of the product at any time, including the right not to release the product shown in this preliminary datasheet

## VMMK-2403 Typical Performance (cont)

( $T_A = 25^\circ\text{C}$ ,  $V_{dd} = 3\text{V}$ ,  $I_{dd} = 38\text{mA}$ ,  $Z_{in} = Z_{out} = 50\ \Omega$  unless noted)

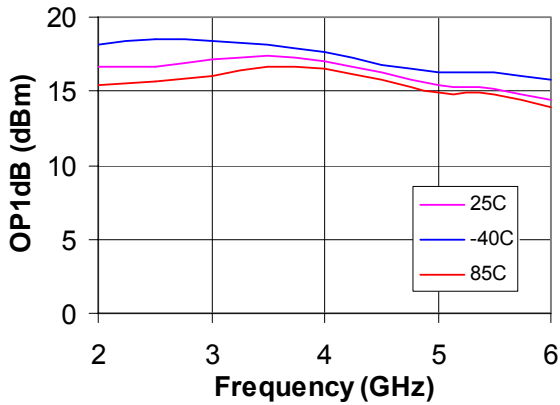

Figure 13. Output P-1dB over Temp

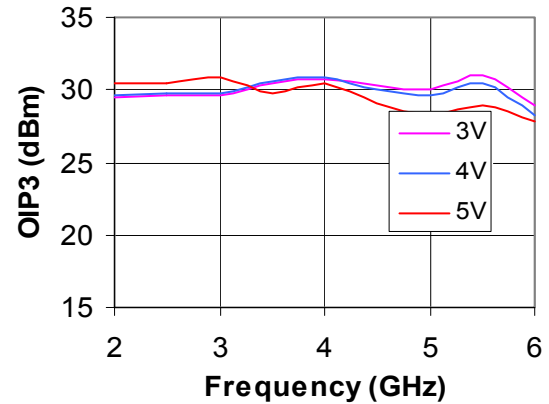

Figure 14. Output IP3 Over Vdd

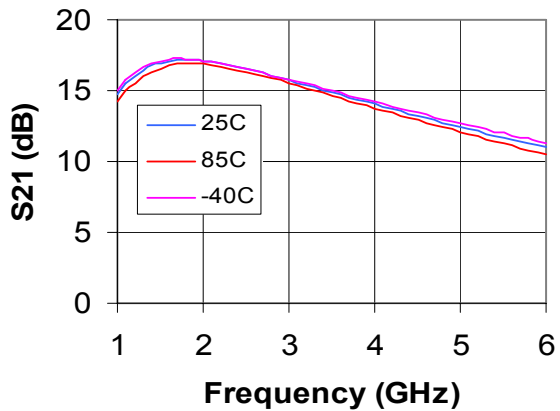

Figure 15. Gain over Temp

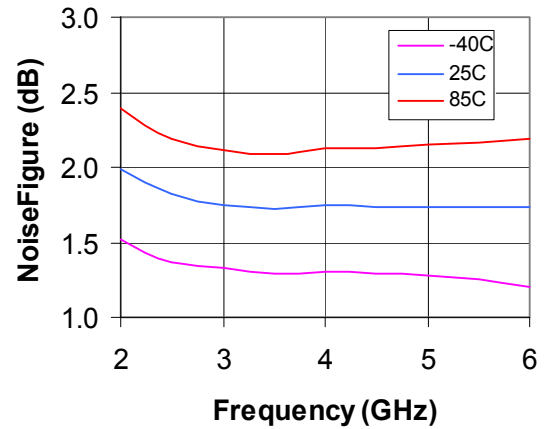

Figure 16 Noise Figure over Temp

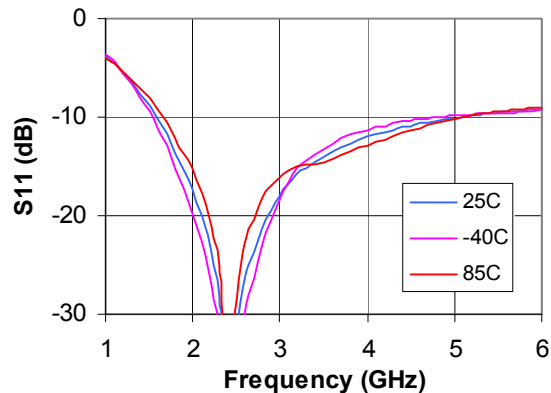

Figure 17. Input Return Loss Over Temp

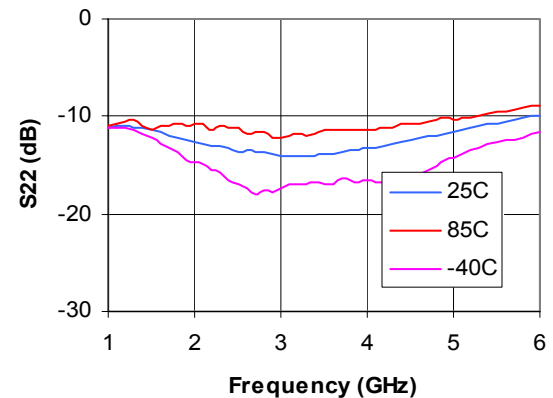

Figure 18. Output Return Loss Over Temp

[www.avagotech.com](http://www.avagotech.com)

Avago, Avago Technologies, and the A logo are trademarks of Avago Technologies, Pte. in the United States and other countries. Copyright © 2006 Avago Technologies Pte. All rights reserved.

**AVAGO**  
TECHNOLOGIES

Pre-released products: Avago Technologies reserves the right to alter specifications, features, functions, markings, manufacturing release dates and general availability of the product at any time, including the right not to release the product shown in this preliminary datasheet

### VMMK-2403 Typical S-parameters

( $T_A = 25^\circ\text{C}$ ,  $V_{dd}=3\text{V}$ ,  $I_{dd}=38\text{mA}$ ,  $Z_{in} = Z_{out} = 50 \Omega$  unless noted)

Freq GHz	S11			S21			S12			S22		
	Mag	dB	Phase	Mag	dB	Phase	Mag	dB	Phase	Mag	dB	Phase
2.0	0.13	-17.40	55.74	7.16	17.09	155.06	0.06	-24.10	42.05	0.24	-12.53	-87.61
2.5	0.03	-31.80	-133.91	6.71	16.53	134.46	0.06	-23.90	30.73	0.21	-13.69	-100.64
3.0	0.12	-18.13	-151.55	6.12	15.74	117.90	0.06	-23.97	23.43	0.20	-14.03	-105.66
3.5	0.20	-14.05	-163.87	5.55	14.88	104.00	0.06	-24.04	19.19	0.20	-13.96	-107.15
4.0	0.25	-12.00	-174.32	5.04	14.05	91.92	0.06	-24.14	15.78	0.22	-13.22	-106.91
4.5	0.29	-10.89	175.98	4.58	13.22	81.08	0.06	-24.14	13.35	0.24	-12.42	-108.59
5.0	0.31	-10.13	167.30	4.19	12.44	71.14	0.06	-24.12	12.04	0.26	-11.58	-110.59
5.5	0.33	-9.59	159.43	3.84	11.69	61.94	0.06	-24.07	10.81	0.29	-10.73	-113.90
6.0	0.35	-9.16	151.41	3.54	10.97	53.04	0.06	-24.01	9.65	0.32	-9.87	-118.40
6.5	0.36	-8.91	143.69	3.26	10.27	44.57	0.06	-23.89	8.81	0.35	-9.03	-123.20
7.0	0.37	-8.69	136.41	3.02	9.59	36.31	0.07	-23.74	8.13	0.39	-8.27	-128.23
7.5	0.38	-8.50	129.27	2.79	8.91	28.19	0.07	-23.58	7.21	0.42	-7.52	-133.56
8.0	0.38	-8.36	122.37	2.58	8.25	20.21	0.07	-23.39	6.48	0.46	-6.81	-139.38
8.5	0.39	-8.21	115.19	2.39	7.56	12.37	0.07	-23.22	5.74	0.49	-6.17	-144.98
9.0	0.39	-8.12	108.46	2.20	6.85	4.43	0.07	-23.06	4.98	0.53	-5.53	-151.26
9.5	0.40	-7.98	101.84	2.02	6.11	-3.50	0.07	-22.83	4.19	0.56	-4.98	-158.01
10.0	0.41	-7.83	95.04	1.84	5.30	-11.35	0.07	-22.60	3.57	0.60	-4.39	-164.68
10.5	0.41	-7.72	88.39	1.66	4.40	-19.19	0.08	-22.34	2.72	0.64	-3.88	-172.30
11.0	0.42	-7.59	82.22	1.48	3.39	-26.92	0.08	-22.09	2.06	0.67	-3.42	179.91
11.5	0.43	-7.42	76.20	1.29	2.22	-34.30	0.08	-21.79	1.40	0.71	-2.99	171.62
12.0	0.43	-7.25	70.01	1.10	0.82	-41.13	0.08	-21.46	0.40	0.74	-2.67	162.75

[www.avagotech.com](http://www.avagotech.com)

Avago, Avago Technologies, and the A logo are trademarks of Avago Technologies, Pte. in the United States and other countries.  
Copyright © 2006 Avago Technologies Pte. All rights reserved.



*Pre-released products: Avago Technologies reserves the right to alter specifications, features, functions, markings, manufacturing release dates and general availability of the product at any time, including the right not to release the product shown in this preliminary datasheet*

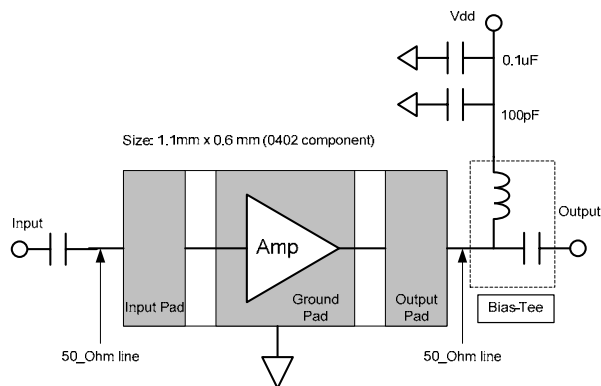

Figure 19. Usage of the VMMK-2403

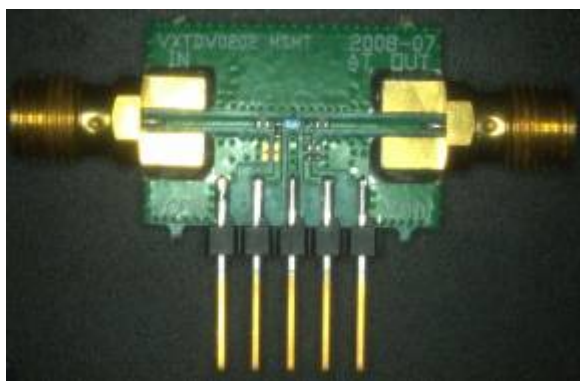

Figure 20. Evaluation/Test Board (available to qualified customer request)

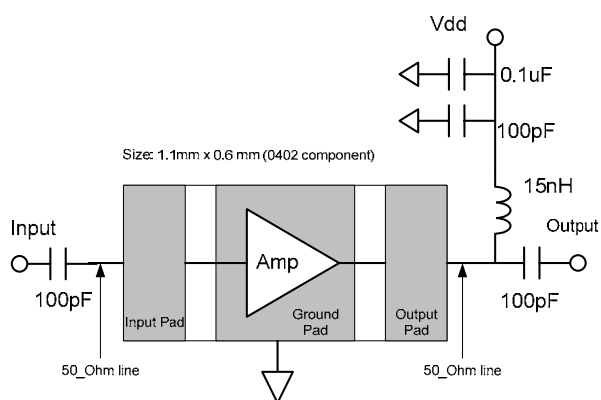

Figure 21. Example application of VMMK-2403 at 3.5GHz

### Biasing and Operation

The VMMK-2403 is normally biased with a positive drain supply connected to the output pin through an external bias-tee and with bypass capacitors as shown in **Figure 19**. The recommended drain supply voltage is 3 V and the corresponding drain current is approximately 38mA. Aspects of the amplifier performance may be improved over a narrower bandwidth by application of additional conjugate, linearity, or low noise ( $\Gamma_{opt}$ ) matching.

Biasing the device at 3V results in slightly lower noise figure. In a typical application, the bias-tee can be constructed using lumped elements. The value of the output inductor can have a major effect on both low and high frequency operation. The demo board uses a 15 nH inductor which provides an optimum value for 2 to 4 GHz operation. If operation is desired at frequencies higher than 4 GHz then a smaller value such as 8.2 nH may be required to keep the self resonant frequency higher than the maximum desired frequency of operation.

Another approach for broadbanding the VMMK-2403 is to series two different value inductors with the smaller value inductor placed closest to the device and favoring the higher frequencies. The larger value inductor will then offer better low frequency performance by not loading the output of the device. The parallel combination of the 100pF and 0.1uF capacitors provide a low impedance in the band of operation and at lower frequencies and should be placed as close as possible to the inductor. The low frequency bypass provides good rejection of power supply noise and also provides a low impedance termination for third order low frequency mixing products that will be generated when multiple in-band signals are injected into any amplifier.

Refer the Absolute Maximum Ratings table for allowed DC and thermal conditions.

## Outline Drawing

### Top and Side View

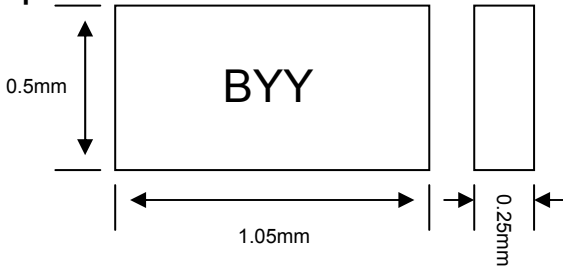

### Bottom View

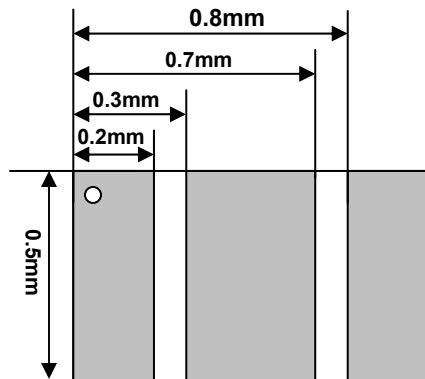

#### NOTES:

- indicates pin 1
- Dimensions are in millimeters
- Pad Material is minimum 5.0 um thick Au

### Suggested PCB Material and Land Pattern

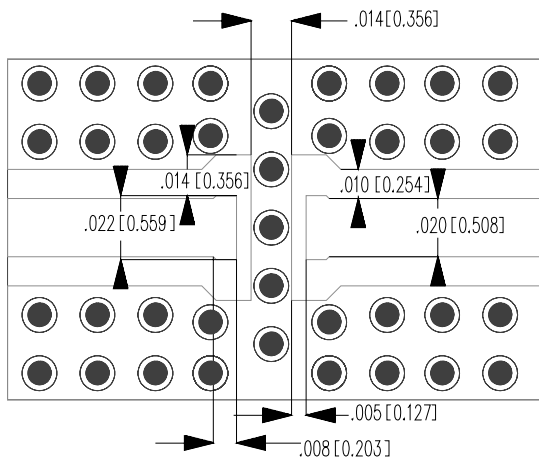

#### NOTES:

- 0.010" Rogers RO4350

## Recommended SMT Attachment

The VMMK Packaged Devices are compatible with high volume surface mount PCB assembly processes.

### Manual Assembly for Prototypes

- Follow ESD precautions while handling packages.
- Handling should be along the edges with tweezers or from topside if using a vacuum collet.
- Recommended attachment is solder paste. Please see recommended solder reflow profile. Conductive epoxy is not recommended. Hand soldering is not recommended.
- Apply solder paste using either a stencil printer or dot placement. The volume of solder paste will be dependent on PCB and component layout and should be controlled to ensure consistent mechanical and electrical performance. **Excessive solder will degrade RF performance.**
- Follow solder paste and vendor's recommendations when developing a solder reflow profile. A standard profile will have a steady ramp up from room temperature to the pre-heat temp to avoid damage due to thermal shock.
- Packages have been qualified to withstand a peak temperature of 280°C for 15 sec. Verify that the profile will not expose device beyond these limits.
- Clean off flux per vendor's recommendations.
- Clean the module with Acetone. Rinse with alcohol. Allow the module to dry before testing.



Note: These devices are ESD sensitive. The following precautions are strongly recommended. Ensure that an ESD approved carrier is used when die are transported from one destination to another.

Personal grounding is to be worn at all times when handling these devices. For more detail, refer to Avago Application Note A004R: Electrostatic Discharge Damage and Control

ESD Machine Model (Class A)  
ESD Human Body Model (Class A)

[www.avagotech.com](http://www.avagotech.com)

Avago, Avago Technologies, and the A logo are trademarks of Avago Technologies, Pte. in the United States and other countries. Copyright © 2006 Avago Technologies Pte. All rights reserved.

**AVAGO**  
TECHNOLOGIES

Pre-released products: Avago Technologies reserves the right to alter specifications, features, functions, markings, manufacturing release dates and general availability of the product at any time, including the right not to release the product shown in this preliminary datasheet

Revision 1.44

Page 8 of 10

### Ordering Information

Part Number	Devices Per Container	Container
VMMK-2403-BLKG	100	Antistatic Bag
VMMK-2403-TR1G	5000	7" Reel

### Package Dimension Outline

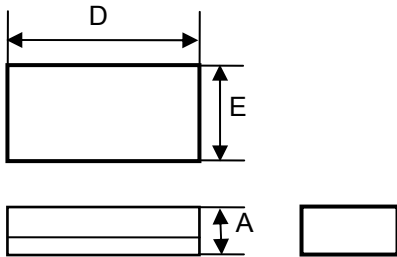

#### Dimensions

Symbol	Min (mm)	Max (mm)
E	0.500	0.566
D	1.004	1.066
A	0.235	0.265

#### Note:

All dimensions are in mm

### Device Orientation

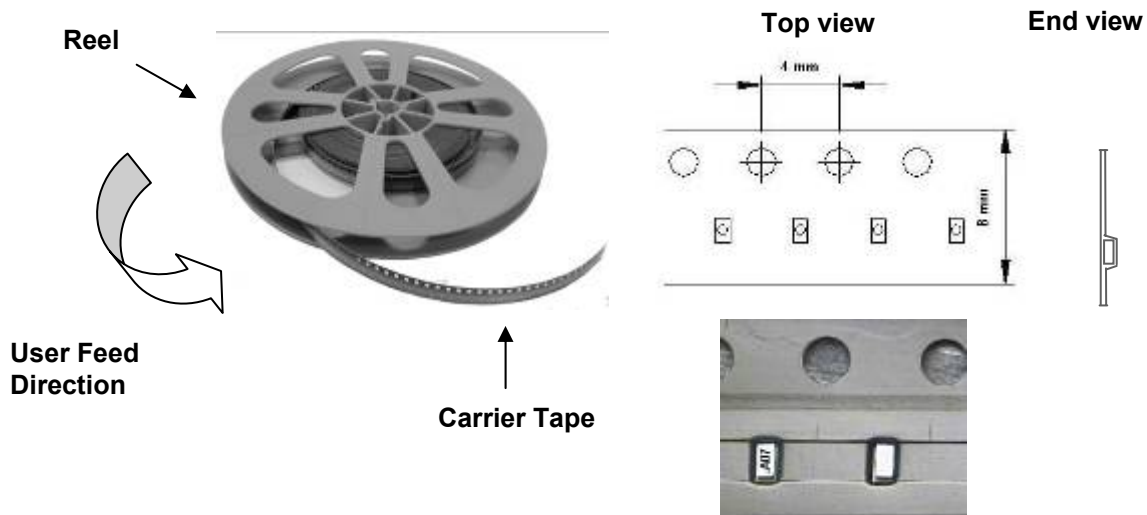

[www.avagotech.com](http://www.avagotech.com)

Avago, Avago Technologies, and the A logo are trademarks of Avago Technologies, Pte. in the United States and other countries.

Copyright © 2006 Avago Technologies Pte. All rights reserved.

**AVAGO**  
TECHNOLOGIES

*Pre-released products: Avago Technologies reserves the right to alter specifications, features, functions, markings, manufacturing release dates and general availability of the product at any time, including the right not to release the product shown in this preliminary datasheet*

Revision 1.44

Page 9 of 10

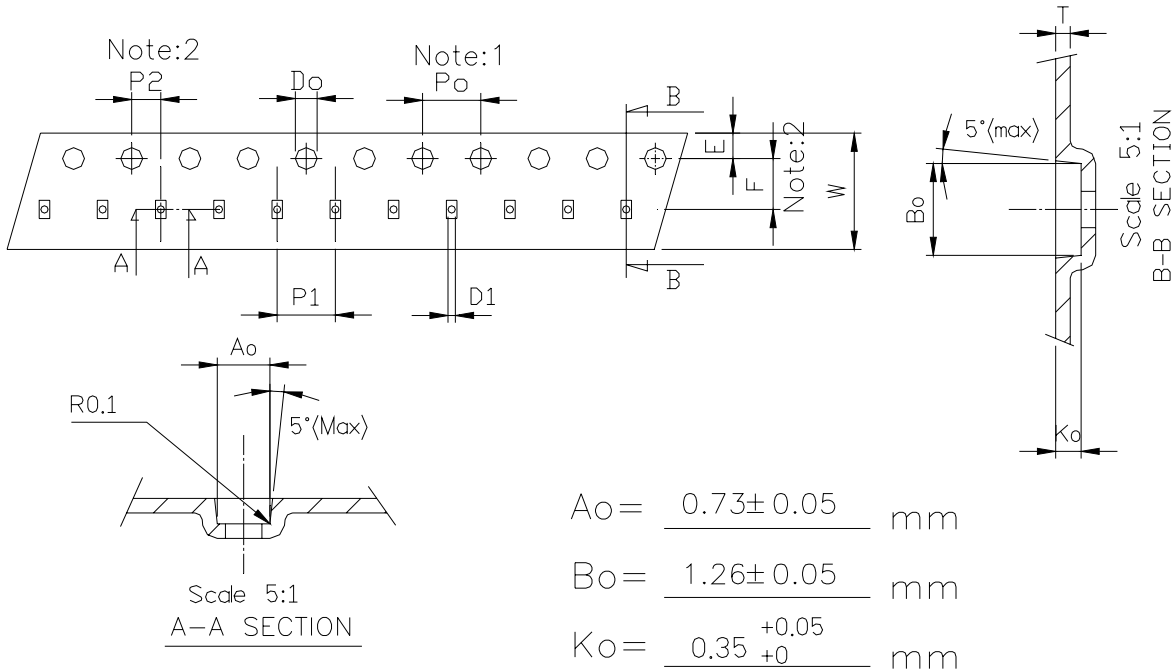

Unit: mm

Symbol	Spec.
K1	-
Po	$4.0 \pm 0.10$
P1	$4.0 \pm 0.10$
P2	$2.0 \pm 0.05$
Do	$1.55 \pm 0.05$
D1	$0.5 \pm 0.05$
E	$1.75 \pm 0.10$
F	$3.50 \pm 0.05$
10Po	$40.0 \pm 0.10$
W	$8.0 \pm 0.20$
T	$0.20 \pm 0.02$

Notice:

1. 10 Sprocket hole pitch cumulative tolerance is  $\pm 0.1$ mm
2. Pocket position relative to sprocket hole measured as true position of pocket not pocket hole.
3. Ao & Bo measured on a plane 0.3mm above the bottom of the pocket to top surface of the carrier.
4. Ko measured from a plane on the inside bottom of the pocket to the top surface of the carrier.
5. Carrier camber shall be not than 1mm per 100mm through a length of 250mm.

For product information and a complete list of Avago contacts and distributors, please go to our Website:

[www.avagotech.com/semiconductors](http://www.avagotech.com/semiconductors)

E-mail: [SemiconductorSupport@avagotech.com](mailto:SemiconductorSupport@avagotech.com)

Data subject to change.

Copyright © 2006 Avago Technologies

[www.avagotech.com](http://www.avagotech.com)

Avago, Avago Technologies, and the A logo are trademarks of Avago Technologies, Pte. in the United States and other countries.

Copyright © 2006 Avago Technologies Pte. All rights reserved.

**AVAGO**  
TECHNOLOGIES

Pre-released products: Avago Technologies reserves the right to alter specifications, features, functions, markings, manufacturing release dates and general availability of the product at any time, including the right not to release the product shown in this preliminary datasheet

Revision 1.44

Page 10 of 10